

AN971_VCM Driver



VCM DRIVER Application Note

This document applies to Giantec VCM driver products: GT9764, GT9767, GT9768, GT9769, GT9772, and GT9778. GT9772 is used as an example in this application note.

1. Theory of Operation

The GT9772 is a fully integrated, 10-bit digital-to-analog converter (DAC) with 120mA output current sink capability. It is intended for driving voice coil actuators in applications such as lens autofocus, image stabilization, and optical zoom. The circuit diagram is shown in Figure 1. A 10-bit current output DAC coupled with Resistor generates the voltage that drives the non-inverting input of the operational amplifier. This voltage also appears across the R_{SENSE} resistor and generates the sink current required to drive the voice coil.

Resistor R_1 and Resistor R_{SENSE} are interleaved and matched. Therefore, the temperature coefficient and any nonlinearity over temperature are matched, and the output drift over temperature is minimized. Diode D1 is an output protection diode.

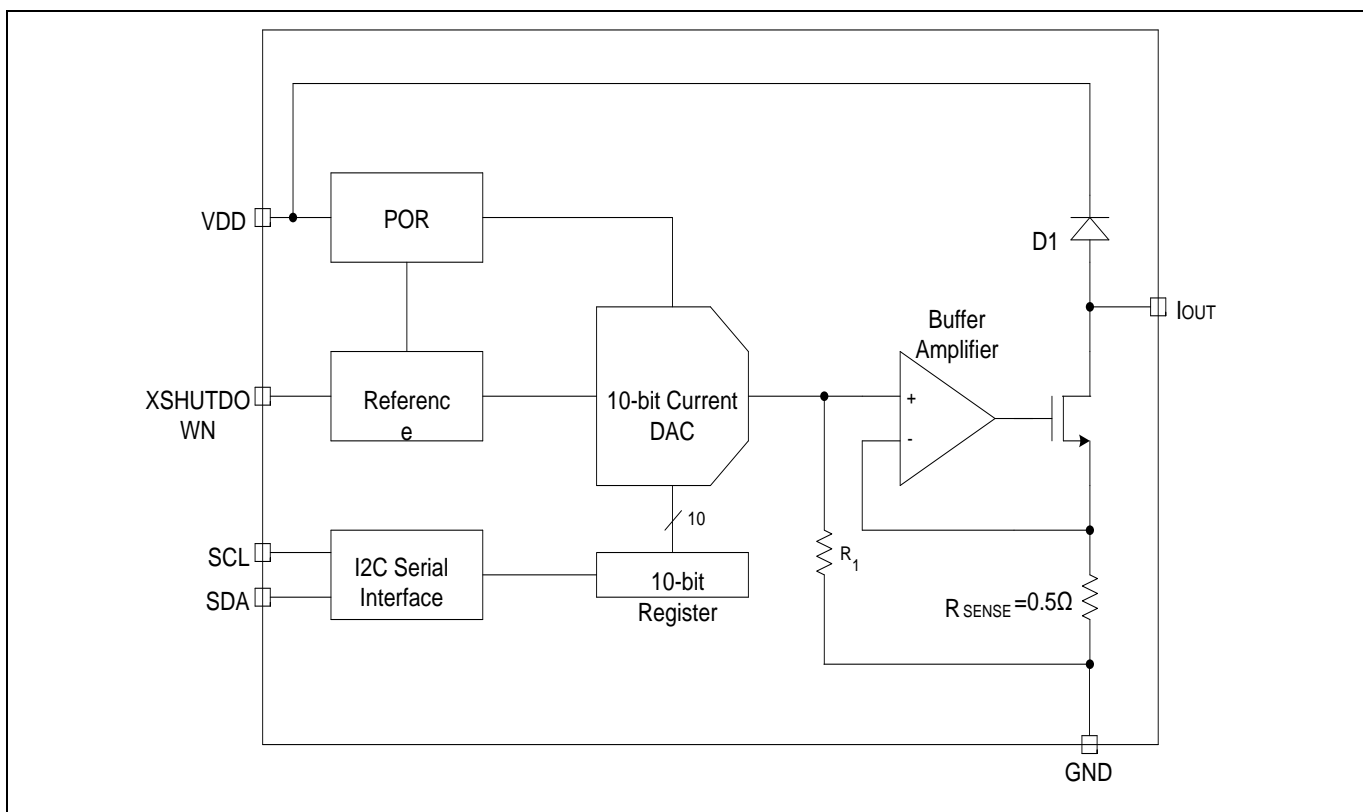

Figure 1. Functional Block Diagram

Copyright © 2010 Giantec Semiconductor Inc. (Giantec). All rights reserved. Giantec reserves the right to make changes to this specification and its products at any time without notice. Giantec products are not designed, intended, authorized or warranted for use as components in systems or equipment intended for critical medical or surgical equipment, aerospace or military, or other applications planned to support or sustain life. It is the customer's obligation to optimize the design in their own products for the best performance and optimization on the functionality and etc. Giantec assumes no liability arising out of the application or use of any information, products or services described herein. Customers are advised to obtain the latest version of this device specification before relying on any published information and prior placing orders for products.



AN971_VCM DRIVER

2, Advanced Actuator Control (AAC) Technology

Mechanical ringing is an inherent problem in voice coil motors. It is an artifact of an underdamped system and is dependent on many factors, but primarily on the integrity of the mechanical springs employed in the actuator assembly.

AAC is a revolutionary autofocus response time and image quality enhancing technology, which has been developed by Giantec and integrated into the GT9772VCM drivers. AAC circuitry applies specialized, patented waveform and application technology to underdamped voice coil motors to reduce mechanical ringing. This technology enables the user to achieve very fast mechanical settling times and, as a result, greatly enhances autofocus response times, image quality, and user experience. This technology is completely proprietary to Giantec and patents are pending.

AAC technology incorporates a wide band of tolerance around the resonant period of the VCM to compensate for manufacturing variability in the mechanical resonance period of the VCM. AAC technology can allow for variations of $\pm 31\%$ (for example, manufacturing variations and variations over time and temperature) in the VCM resonant period while still greatly enhancing autofocus response times and image quality. This band of tolerance varies, depending on the AAC option used.

Each of the four AAC options achieves a different actuation time. A faster actuation time leads to a narrower resonant period tolerance band (see Figure 2 and Table 1).

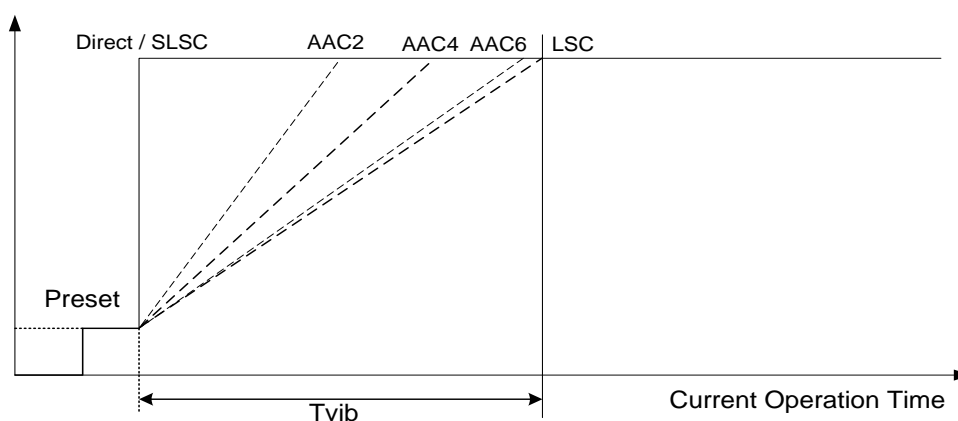

Figure 2. AAC Current Operation Time

Table 1 Current Operation Times and Tolerances of AAC Options

AAC Option	Current Operation Time ⁽¹⁾	Frequency Tolerance ⁽²⁾
AAC2 mode	0.50Tvib	$\pm 9\%$
AAC4 mode	0.72Tvib	$\pm 24\%$
AAC6 mode	0.96Tvib	$\pm 31\%$
SLSC mode	1Tvib	$\pm 16\%$

(1) Operationtime: Driver's current moving time

(2) This is a design spec. FrequencyTolerance can be variable according to mechanical characteristics of each VCM

(3) Tvib = vibration period of VCM

Figure 3 illustrates all the output modes of the GT9772 and clearly shows the significant impact that Linear and AAC



AN971_VCM DRIVER

technology has on the settling time and the amount of mechanical ringing and overshoot in a sample VCM.

Figure 3 is the testing result of AAC mode operation with VCM

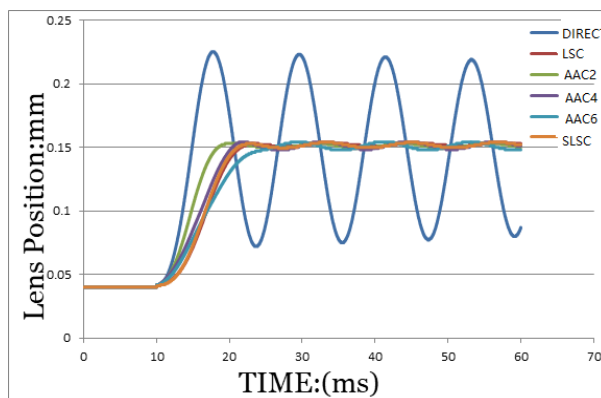

Figure 3. Comparing Direct, Linear, and AAC Modes Using a Same VCM

3. Power Up/Down and Voltage Drop

Power on and power down sequence is very critical for the VCM driver, especially in the case of frequent power ups and downs.

Figure 4 and Table 2 illustrate the power on & power down sequence and timing for Giantec's VCM driver.

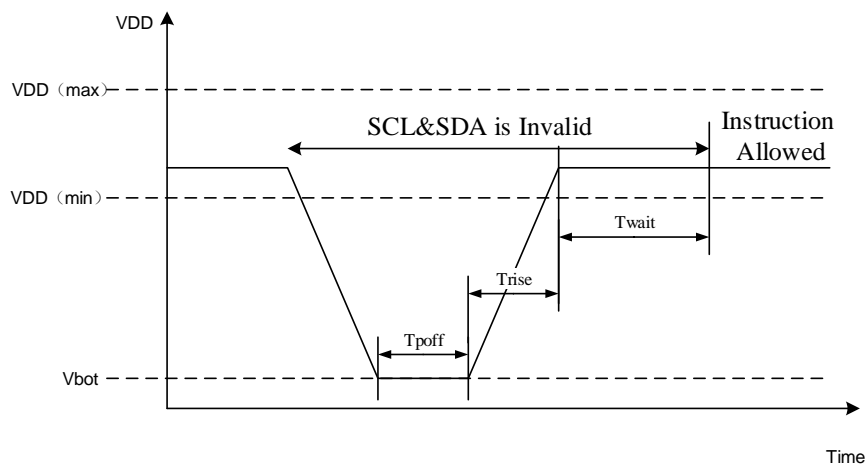

Figure 4. Power down-up Timing

Table 2 Power on/power off timing

Symbol	Parameter	min	max	unit
V _{bot}	VDD at power off		0.2	V
T _{pooff}	VDD at power off time	100		mS
T _{rise}	V _{bot} to VDD min	50	200	μS/V
ST _{wait}	VDD Min to Instruction	2		mS

* All parameters may be changed after the design or process change.



AN971_VCM DRIVER

4. VDD Bypass Capacitance

The power supply of the GT9772, or the regulator used to supply the GT9772, should be decoupled. If the power supply or regulator supply is well regulated and clean, such decoupling may not be required. The GT9772 should be decoupled locally with a 0.1~1.0 μ F ceramic capacitor, and this 0.1~1.0 μ F capacitor should be located as close as possible to the VDD pin. The 0.1~1.0 μ F capacitor should be ceramic with a low effective series resistance and effective series inductance. The 0.1~1.0 μ F capacitor provides a low impedance path to ground for high transient currents.

